

LOW-RESOURCE DELAYLESS SUBBAND ADAPTIVE FILTER USING WEIGHTED OVERLAP-ADD

Hamid Sheikhzadeh, Robert L. Brennan, Zamir Khan, and Kevin R. L. Whyte

AMI Semiconductor Canada Company, 611 Kumpf Drive, Unit 200, Waterloo, Ontario, Canada N2V 1K8
email: {hsheikh, robert.brennan}@amis.com

ABSTRACT

A delayless structure targeted for low-resource implementation is proposed to eliminate filterbank processing delays in subband adaptive filters (SAFs). Rather than using direct IFFT or polyphase filterbanks to transform the SAFs back into the time-domain, the proposed method utilizes a weighted overlap-add (WOLA) synthesis. Low-resource real-time implementations are targeted and as such do not involve long (as long as the echo plant) FFT or IFFT operations. Also, the proposed approach facilitates time distribution of the adaptive filter reconstruction calculations crucial for efficient real-time and hardware implementation. The method is implemented on an oversampled WOLA filterbank employed as part of an echo cancellation application. Evaluation results demonstrate that the proposed implementation outperforms conventional SAF systems since the signals used in actual adaptive filtering are not distorted by filterbank aliasing. The method is a good match for partial update adaptive algorithms since segments of the time-domain adaptive filter are sequentially reconstructed and updated.

1. INTRODUCTION

Subband adaptive filters (SAFs) have become viable alternatives to full-band (time-domain) adaptive filtering as a result of their superior computational advantages and faster convergence. To avoid excessive aliasing, SAFs are frequently implemented on oversampled filterbanks. SAFs do, however, incur extra delay in the signal path due to filterbank analysis/synthesis. A number of attempts to reduce the delay problem in SAFs have been reported.

Morgan and Thi [1] introduced a method of reconstructing the subband filter back into the time-domain. Consider a time-domain adaptive filter (TAF) of length L , a uniform DFT-modulated filterbank with K subbands decimated by R and oversampled by $OS = K/R$ (for critically sampled cases $R = K$), and SAFs of length $M = L/R$. This method first transforms the SAFs into the frequency-domain by a DFT of length M , appropriately stacks the results to obtain a DFT array of length L , and inverse transforms the DFT array back into the time-domain to obtain a TAF suitable for adaptive filtering. In [2], the authors expose a weakness in Morgan's method leading to the production of spectral nulls in the passband of the implied synthesis filter. Two variations to the method (called DFT-2 Stacking and DFT-FIR Stacking) are proposed to mitigate this weakness. DFT-2 Stacking simply involves zero-padding prior to DFT and stacking. In DFT-FIR, the SAFs are processed through a polyphase-FFT synthesis filterbank. In [3], a linear weight transform method is introduced. The method employs a linear matrix transformation of the subband filters using both analysis and synthesis filters to recover the TAF. A variation [4] following the steps of Morgan's method employs the Hadamard transform to reconstruct the TAF.

In [5] a new method of transferring the SAFs to time-domain is presented utilizing maximally decimated (QMF) perfect reconstruction filterbanks. Accordingly, the filterbank prototype filter must be constrained to be a Nyquist(K) filter. As a result, the subband analysis filters become simple fractional delay filters. A polyphase

filterbank is used to reconstruct the TAF. For real-time and hardware implementations however, oversampled SAFs (OS-SAFs) are preferred due to their simplicity and low-delay characteristics.

As low-resource real-time implementation is targeted in this research, the proposed method is based on the DFT-FIR idea, i.e. the TAF is obtained by employing the subband adaptive filter taps as input signals to a synthesis filter [2,3]. In [2] they use a polyphase-FFT structure to implement the DFT-FIR method for both critically sampled and two-times oversampled filterbanks. It is well known that the polyphase-FFT synthesis process is more amenable to stream processing computing environments [6] and is not efficient for real-time low-resource hardware implementation. In contrast, the weighted-overlap add (WOLA) synthesis process is more amenable to a block processing environment [6]. In addition, an efficient ultra-low power implementation of WOLA analysis/synthesis filterbanks is already available [7]. Thus the method introduced in this research is fully compatible with low-resource WOLA filterbanks.

In this paper we propose the use of the WOLA synthesis method (implemented with an oversampled filterbank) to reconstruct the TAF. Only an IFFT of length K is employed in the proposed method and due to the nature of the WOLA synthesis, the reconstruction process is distributed in time rendering it suitable for real-time implementation. The method is arranged such that segments of the TAF may be used as they become available in time. This makes the method a perfect match for sequential partial update algorithms (described later) that are often integral parts of low-resource implementations. The proposed WOLA synthesis of the subband filters is efficiently implemented on an oversampled filterbank that also benefits from the WOLA implementation for its analysis stage. The system is designed and described for an echo cancellation set up though it could be used for other adaptive applications such as active noise cancellation or adaptive feedback cancellation.

Section 2 describes the proposed algorithm. Evaluation results including the usage of partial update adaptive methods are presented in Section 3, and conclusions of the work are discussed in Section 4.

2. WOLA SYNTHESIS FOR FILTER RECONSTRUCTION

Depicted in Fig. 1 is a typical delayless SAF structure [1-4]. At the output of adaptive processing blocks (APBs in the figure), the subband adaptive filters $P_k(z)$, $k = 0, 1, \dots, K-1$ are obtained. Rather than reconstructing the output signal as in typical SAF systems, the adaptive filters are passed to a weight transformation stage to obtain the time-domain adaptive filter $P(z)$ to be used to filter the reference signal $x(n)$ in the time-domain. Assuming a synthesis filter set $F_k(z)$, $k = 0, 1, \dots, K-1$, in the DFT-FIR approach the TAF is obtained by passing the SAFs through a synthesis filterbank as [2,3]

$$P(z) = \sum_{k=0}^{K-1} F_k(z) P_k(z^R) z^{Ls/2}$$

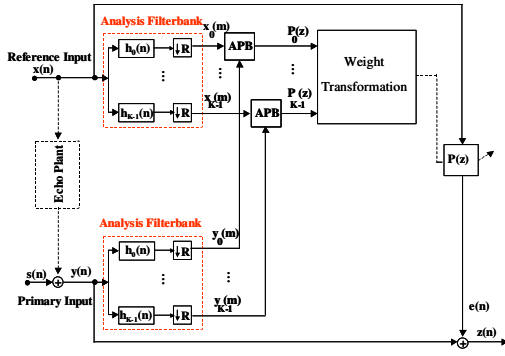

Figure 1: Delayless SAF system using oversampled filterbanks, employing weight transform for time-filter reconstruction.

where R is the filterbank decimation factor, and $F_0(z)$ is the prototype filter of the filterbank, bandlimited to π/R . Synthesis filters are obtained through DFT modulation of the prototype filter as $F_k(z) = F_0(zW^k)$ where $W = e^{-j2\pi/R}$. The term $z^{Ls/2}$ is added to compensate for delay of the synthesis filter of length Ls .

As mentioned before, the DFT-FIR uses a polyphase-FFT structure to reconstruct the TAF through a weight transform of the SAF set. We propose a different approach whereby the TAF is reconstructed through a WOLA synthesis of the SAFs. This method is more amenable to a block processing approach and more compatible to hardware implementation. Basically, this method treats the SAFs $p_k(m)$, $k=0,1,\dots,K-1$, $m=0,1,\dots,M-1$ as a set of K subband signals, and passes them through an oversampled filterbank synthesis stage as shown in Fig. 2. To efficiently implement the oversampled synthesis stage, we use the WOLA implementation as depicted in Fig. 3. For further explanation, consider the SAFs all included in an SAF matrix P , with elements defined as $P(k,m) = p_k(m)$, $m=0,1,\dots,M-1$, $k=0,1,\dots,K-1$. The matrix is set as input to the synthesis stage, one column at every subband time-tick. We call this method of TAF reconstruction “sequential synthesis”. As depicted in Fig. 3, the WOLA synthesis starts with taking an IFFT of each column (of length K) of the SAF matrix. After the IFFT, and proper circular shifting, the vectors of length K are periodically extended to obtain a vector as long as the synthesis window. Next this result is multiplied by the synthesis window followed by an overlap-add operation. Both evenly-stacked FFT and oddly-stacked FFTs may be used. Odd stacking requires an extra sign sequencer to be employed at the final stage. The WOLA synthesis is well described in [6-7]. Assuming aliasing is low in the analysis stage, the SAFs can be shown to converge to the Wiener solution. As a result, the solution will be almost independent of the analysis filter design. Thus the synthesis filter set $F_k(z)$, $k=0,1,\dots,K-1$ should be designed independently of the analysis filter set to constitute a near perfect-reconstruction set. To obtain the TAF, the output buffer in Fig. 3 is first zeroed out. After reading in the input SAF matrix (one column per subband clock tick), the first $Ls/2$ samples of the output are discarded. The next L output samples produced a block at a time (R time-samples) constitute the TAF. Thus it takes L/R input (subband) clock ticks to obtain the TAF. Through optimized implementation (not described here for brevity) it became possible to avoid the initial $Ls/2$ sample delays between consecutive filter reconstructions. The total input-output delay for the TAF filter reconstruction is thus $(La+Ls)/2$ samples where La denotes the analysis window length. This delay is not seen in the signal path; rather the optimal filter for the reference and primary signals is delayed by this amount. When the echo plant varies slowly (relative to

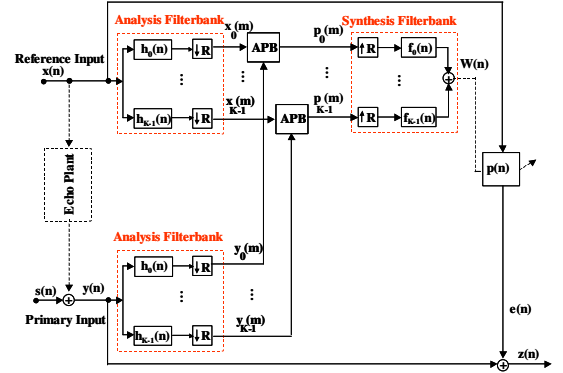

Figure 2: Proposed Reconstruction of the TAF through WOLA synthesis of the SAFs.

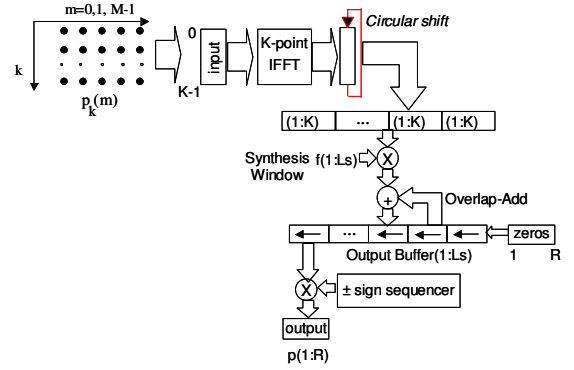

Figure 3: Details of the WOLA filterbank reconstruction.

this reconstruction delay), this delay does not degrade the system performance. It is possible to minimize the delay by choosing shorter analysis and synthesis windows as long as distortions in the time-filter due to the reconstruction process are kept within a tolerable range.

Note that in the conventional SAF systems shorter analysis/synthesis windows will lead to increased output signal degradation since all signals pass through the complete filterbank [8]. By contrast, in the proposed delayless SAF system, signals are passed through the analysis filterbank only to obtain the adaptive filter. As a result, the adverse effects of shorter analysis/synthesis windows on output signal quality is much less pronounced. It is also possible to further reduce the TAF reconstruction delay to only $La/2$ samples if one is ready to perform filterbank reconstruction of the whole SAF matrix P for every output block. We call this method of TAF reconstruction “batch synthesis” as opposed to the “sequential synthesis” described in this section. Batch synthesis will increase the computation cost from a single WOLA synthesis (per output block) in the sequential synthesis to M WOLA synthesis operations. It is also possible to sequentially reconstruct more than one (but less than M) columns of matrix P at every subband time-tick if the computational resources permit.

3. SYSTEM EVALUATION

We evaluate the WOLA filter reconstruction process for a filterbank set up of: analysis and synthesis window lengths of $La=64$, and $Ls=128$ samples with $K=16$ subbands and decimation rate of

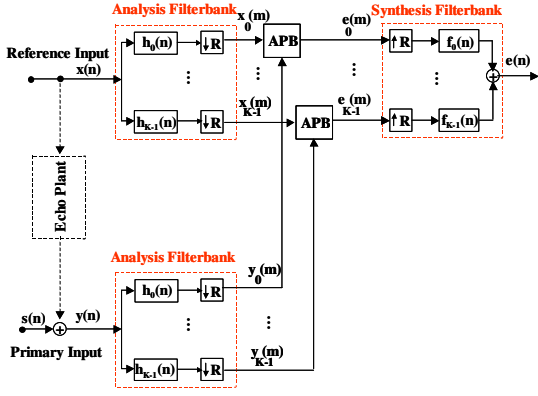

Figure 4: Block diagram of the conventional oversampled SAF system applied to echo cancellation.

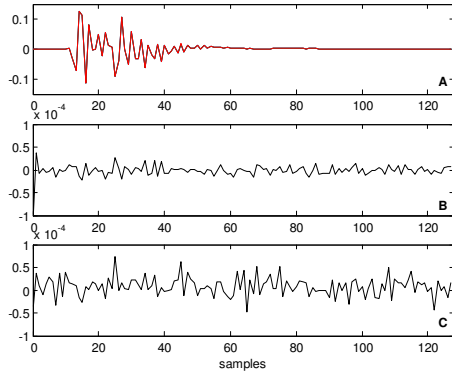

Figure 5: (A) Time-domain echo plant, and the reconstructed plant with SGS-PAP adaptation, for $D=1, 8$, and (B) error in reconstructed TAFs for $D=1$ and (C) error for $D=8$.

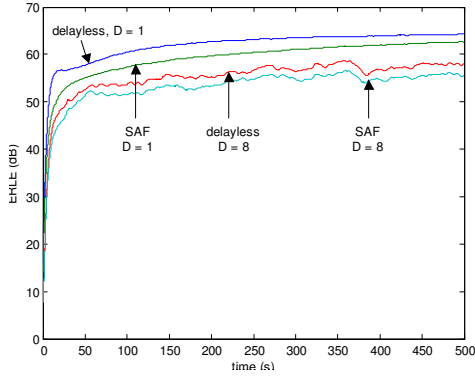

Figure 6: ERLE results for SGS-PAP adaptation with $D=1, 8$, for conventional SAF and the proposed delayless SAF algorithms.

$R=4$. Notice that the analysis filter is shorter in length (and wider in frequency domain) compared to the synthesis filter. This was chosen to provide better excitation in the analysis filter transition region leading to better convergence behavior as reported in the literature [9]. Each SAF $p_k(m)$ is of length $M=32$ resulting in a 16×32 SAF matrix P . For comparison, the same filterbank setup was also employed for the conventional oversampled SAF system with the WOLA implementation (described in [8] and [10]) depicted in Fig. 4. The echo plant was the eighth plant of the ITUT G. 168

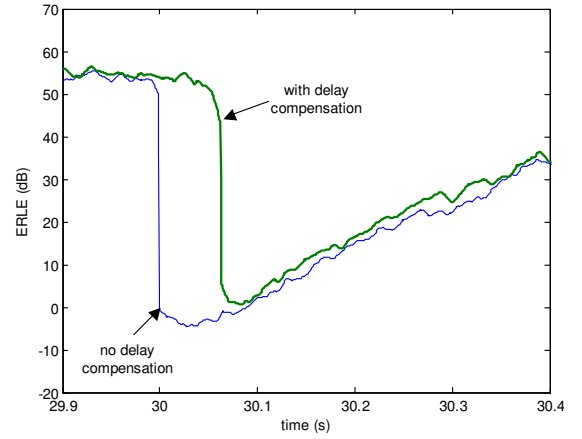

Figure 7: ERLE (dB) versus time for WOLA filter reconstruction with and without delay compensation.

standard [11], the Echo Return Loss (ERL) was 10 dB, and random white noise was used at the reference input without any near-end disturbance.

For subband adaptation, the Gauss-Seidel Pseudo-Affine Projection (GS-PAP) [12] with an affine order of two was employed. The method provides fast convergence and is simple enough to be targeted for a low-resource real-time implementation. For our intentions, GS-PAP is also superior to the Fast Affine Projection Algorithm (FAPA) since unlike the FAPA that operates on a transformed adaptive filter, the GS-PAP directly provides the adaptive filter itself [10,12]. To demonstrate the capability of the proposed WOLA filter reconstruction algorithm in matching sequential update algorithms, sequential update GS-PAP (SGS-PAP described in [10]) was also used for subband adaptation. The sequential decimation factor of the SGS-PAP was chosen to be eight ($D=8$). This means only one polyphase component (of length $32/8=4$ taps) out of a total of 8 components of each SAF is adapted at each subband clock tick. For $D=1$, the SGS-PAP is obviously the same as GS-PAP. In the delayless algorithm, a block of R new samples of the TAF is available every subband tick. This new block is used to update the TAF as soon as it becomes available. This way a smooth and continuous filter reconstruction is achieved.

Fig. 5 depicts the ERLE results for the conventional SAF system (Fig. 4) as well as the proposed delayless WOLA filter synthesis algorithm (Figs. 2 and 3), employing SGS-PAP with $D=1, 8$. As expected, the delayless method achieves a greater ERLE compared to the SAF system, partially due to the fact that the input signals are not passed through the WOLA analysis/synthesis stages. This is consistent with the result and analysis presented in [2-3]. Note that the SGS-PAP method shows a slight performance degradation for $D=8$ (for both the SAF and the delayless methods) since the subband adaptive filters are updated at a much lower rate. Adaptation cost is, however, reduced by a factor of $D=8$.

Using the proposed WOLA synthesis, the TAF was synthesized. Fig. 6-A shows the synthesized time-filter for SGS-PAP adaptation with $D=1, 8$, super-imposed on the ITUT plant. As shown the three impulse responses are almost identical. To observe the differences, Figs. 6-B and 6-C depict time-domain differences between each of the synthesized time-filters and the ITUT plant for $D=1, 8$. As shown, the differences are negligible in both cases, and higher for $D=8$ as predicted by the ERLE results.

Finally, comparing the proposed method with other delayless SAF systems, note that TAF synthesis through WOLA filterbank is mathematically identical to the polyphase filterbank DFT-FIR syn-

thesis proposed in [2]. As a result, the two methods (in simulation and with double-precision arithmetic) perform almost identically when identical prototype filters are employed.

In a real hardware implementation, however, the polyphase filterbank synthesis of [2] and the proposed WOLA synthesis should be compared based on their suitability. As mentioned before, the WOLA structure is more amenable with a block processing system [6]. As illustrated in Fig. 3, for every input vector, all the processes (after the IFFT) occur sequentially to generate R samples of output. All various blocks of Fig. 3 can thus operate synchronously with a single subband clock, and there is no need to extra buffering. Since the WOLA filterbank is a block processing system, every slice generated from the IFFT block that must be overlap-added to the previous results has a common exponent. This greatly simplifies the architecture, reducing power and enhancing throughput [7]. The same does not hold for straightforward polyphase implementation of [2] since it is a stream processing method. In the polyphase filterbank synthesis of [2], a separate convolution of one of K polyphase synthesis filters (with one of the K subband signals) has to occur for each sample of output. To do this, K different data buffers have to be updated. To summarize, the proposed WOLA synthesis of Fig. 3 provides a simpler, more modular structure for real-time hardware implementation [7].

3.1 Tracking Properties

As explained in Section 2, in the proposed algorithm the TAF is obtained with a delay relative to the input signal. The amount of delay depends on the method of filter reconstruction. For sequential synthesis the delay is $(La + Ls)/2$ samples while for batch synthesis it is $La/2$ samples. All of the delayless SAF methods reviewed in Section 1 have to deal with a plant reconstruction delay. The delay leads to a "synchronization problem" between the input signals and the plant, causing problems in tracking a dynamic plant. The extent of the problem depends on the plant time-dynamics and the TAF reconstruction delay.

To demonstrate the effects of the delay, we simulated the system with the same system set up and input signals as described in the previous section with the following changes. The echo plant was switched to a new plant after 30 seconds through the experiment. With the employed analysis/synthesis filters used in the experiments, tracking problems were barely observable due to the low reconstruction delay of the system. Thus, the analysis and synthesis window lengths were increased to $La = 1024$ and $Ls = 256$ samples to better observe the effects of the delay. To simplify the analysis, batch synthesis was used for TAF WOLA reconstruction. This leads to a filter reconstruction delay of $La/2 = 512$ samples. Delaying the input signals by the same amount so that they are synchronized with the plant could compensate for the filter reconstruction delay. Of course this is counter productive as it creates delays in an otherwise delayless system. Fig. 7 depicts the ERLE results using the WOLA reconstructed TAF, around the time of plant change. The ERLE drops at 30 seconds, and stays low for around 64 msec (corresponding to 512 samples of delay) before it starts to rise again. This low-time of ERLE causes a drop in echo cancellation performance and creates artifacts in the output. Repeating the experiment with delay compensation, the ERLE drops later and start to rise right away as shown in the figure. The echo plant swap is unlikely to happen in practice; rather gradual plant variations might occur. Nevertheless the above experiment serves to underline the potential for tracking difficulties as the reconstruction delay increases. The problem is not specific to the proposed method and exists in all the delayless systems described in this paper.

We have minimized the filter reconstruction delay problem in our system (described in Section 3) through using short analysis and

synthesis filters. As discussed in Section 2, the adverse effects of short filters on system performance are much less pronounced in the proposed method compared to typical SAF systems.

4. CONCLUSION

A delayless method for adaptive filtering through SAF systems is proposed. The method, based on WOLA synthesis of the SAFs, is very efficient and is well mapped to a low-resource hardware implementation. The performance of an open-loop version of the system was compared against a conventional SAF system employing the same WOLA analysis/synthesis filterbanks, with the proposed delayless system offering superior performance but at greater computational cost. The performance is identical to the DFT-FIR delayless SAF system that employs straightforward polyphase filterbanks. However, the proposed WOLA-based TAF synthesis offers a superior mapping to low-resource hardware with limited-precision arithmetic. Also the WOLA adaptive filter reconstruction may easily be spread out in time simplifying the necessary hardware. This time-spreading may be easily combined with partial update adaptive algorithms to reduce the computation cost for low-resource real-time platforms.

REFERENCES

- [1] D. R. Morgan and J.C. Thi, "A delayless subband adaptive filter structure", *IEEE Trans. on Sig. Proc.*, Aug. 1995, vol. 43, pp. 1819-1830.
- [2] J. Huo et al., "New weight transform schemes for delayless subband adaptive filtering", *Proc. of IEEE Global Telecom. Conf.*, 2001, pp. 197-201.
- [3] L. Larson et al., "A new subband weight transform for delayless subband adaptive filtering structures", *Proc. of IEEE DSP workshop*, Oct. 2002, pp. 201-206.
- [4] N. Hirayama et al., "Delayless subband adaptive filtering using the hadamard transform", *IEEE Trans. on Sig. Proc.*, Jun. 1999, vol. 47, pp. 1731-1734.
- [5] R. Merched et al. "A new delayless subband adaptive filter structure", *IEEE Trans. on Sig. Proc.*, Jun. 1999, vol. 47, pp. 1580-1591.
- [6] R. E. Crochiere and L. R. Rabiner, *Multirate digital signal processing*, Prentice-Hall, NJ, 1983.
- [7] R. L. Brennan, and T. Schneider, "A Flexible Filterbank Structure for Extensive Signal Manipulations in Digital Hearing Aids," *Proc. IEEE ISCAS*, 1998, pp. 569-572.
- [8] H. Sheikhzadeh, H. R. Abutalebi, R. L. Brennan, and J. Sol-lazzo, "Performance Limitations of a New Subband Adaptive System for Noise and Echo Reduction", *Proc. of IEEE ICECS*, 2003.
- [9] P. L. De León, II and D. M. Etter, "Experimental Results with Increased Bandwidth Analysis Filters in Oversampled, Subband Acoustic Echo Cancelers," *IEEE Sig. Proc. Letters*, Jan. 1995, vol. 2, pp. 1-3.
- [10] H. Sheikhzadeh, K. Whyte, and R. L. Brennan, "Partial update subband implementation of complex pseudo-affine projection algorithm on oversampled filterbanks", *accepted, to be presented at ICASSP 2005*.
- [11] Recommendation ITU-T G.168, Digital Network Echo Cancellers, Int'l Telecommunication Union, 2000.
- [12] Albu and A. Fagan, "The Gauss-Seidel Pseudo Affine Projection Algorithm and its Application for Echo Cancellation," *37th Asilomar Conf. Sig. Sys. & Comp.*, Pacific Grove, Calif., Nov. 2003.